

FLY HIGH
FATSAC

Pro Series

Barefoot International & Fly High Mfg.
3879 North Richards Street
Milwaukee, WI 53212

Phone: 414-964-3668 / 800-932-0685 Fax: 414-964-5767
E-Mail: biph@mindspring.com Web: www.fatsac.com

The Cage Installation Instructions

⚠ WARNING ⚠

FAILURE TO ADHERE TO ALL WARNINGS COULD CAUSE DAMAGE TO EQUIPMENT OR VEHICLE, PERSONAL INJURY OR EVEN DEATH.

BE AWARE OF YOUR SURROUNDINGS AND ALWAYS STAY CLEAR OF BRIDGES, OVERHANGING TREES, LOW HANGING POWER LINES AND ANY OTHER OBSTACLES • DO NOT TOW THE BOAT WITH THE CAGE INSTALLED • DO NOT USE TO PULL KITES, PARA SAILORS OR STRANDED BOATS • BE SURE TO CHECK ALL HARDWARE FOR WEAR AND PROPER INSTALLATION PRIOR TO EACH USE

⚠ WARNING ⚠

THE USE OF THIS PRODUCT INVOLVES INHERENT RISKS OF INJURY OR DEATH. TO REDUCE THESE RISKS THE INDIVIDUAL MUST ALWAYS STAY WITHIN THEIR LIMITS AND AT SPEEDS THAT DO NOT EXCEED THEIR LEVEL OF SKILL. THIS PRODUCT ALLOWS WAKEBOARDERS TO ATTAIN MORE HEIGHT AND IT IS STRONGLY RECOMMENDED THAT EACH USER TAKES A SLOW APPROACH TO THE WAKE UNTIL THEY FULLY ADJUST TO THE DIFFERENCE IN FEEL AND HOW THE CAGE WORKS.

- 1- ***Read through all directions and warnings completely before installing this product.***
- 2- Determine where you plan to install The Cage. The center of the boat is best. (Figure 1).
- 3- It's easiest to assemble The Cage on the ground (use a tarp to prevent scratches).
- 4- Pin the rear mount bases to the rear bars using 2" hitch pins.
- 5- Slide the adjustable horizontal bar into the vertical bars.
- 6- Now you must set the distance between the rear bars equal to the width of the boat where the rear mount bases will be installed. Measure the distance between the boat gunnels and use the pins in the horizontal section to adjust the distance accordingly.

NOTE- Make sure the adjustable horizontal bar is centered between the verticals bars.

- 7- Pin the front bars to the rear bars using 2" hitch pins. (Figure 1)
- 8- Now pin a front mount base to the foot of each front arm.

FIG. 1



9- With the help of your friends (one person on each corner) raise The Cage and walk it over the boat from the rear. Use rags / towels to rest it on the boat (try to avoid using a shop rags because they may have abrasive materials in them). Place it on the boat where it will be installed. Now carefully fold it down to see where and how it rests. Does everything look good?

10- Once it's set, check to ensure that the underside is clear of any obstructions such as wires, cables, etc. Also make sure the under-plates will fit flush under the gunnels.

11- To mark where you will need to drill for each of the mounting points, you will need to use a pencil to lightly mark around each mount base. These marks will be used to align the mount bases and mark the holes where you need to drill.

12- Lift the cage and walk it off the rear of the boat.

13- Remove one front and rear mount base from The Cage and use the markings you made in step 12 to align the bases and mark the holes for your drilling points.

14- PRIOR TO DRILLING: Double check to ensure that the underside is clear and that the under plate will fit flush under the gunnel. If everything is clear, drill 1/2" holes through your markings.

NOTE- Use anti-seize on the bolts

15- Remove the remaining mount bases from The Cage and place them where they will be installed. Insert the proper bolts through the each mount base. (Figures 2 & 4)

16- Slide the under-plates over the bolts on the underside of the gunnel. Use a washer and nut to secure the mount bases. Tighten the rear mount base bolts firmly. *Don't completely tighten the front mount bases yet.* You want to allow them to turn slightly for aligning them with the front bars. (Figure 5)

17- Now lift The Cage and walk it over the boat. Pin the rear bars to the rear mount bases.

18- To reduce vibration in The Cage, you can adjust the rear bars outward using the adjustable horizontal bar. There should be slight outward pressure to help make The Cage rigid. Don't forget that the horizontal bar must be centered!

19- Now align the front bars to their mount bases (Figure 5). Once they are lined up, finish tightening the bolts firmly.

20- Double check to make sure you tightened all the bolts firmly.

NOTE- To fold The Cage down: 1) Pull the pins from the front mounts. 2) Lower it to the rear of the boat. 3) Fold the arms in

FIG. 2

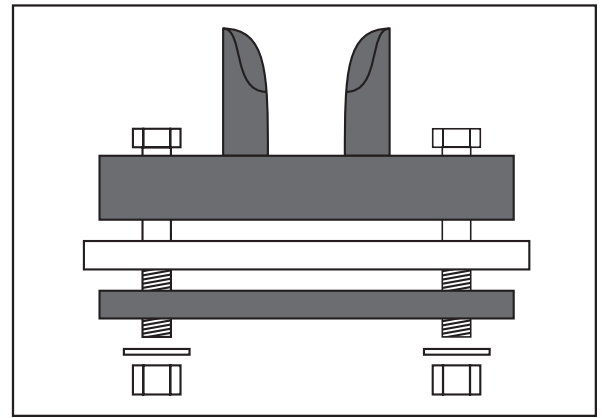

FIG. 3



FIG. 4

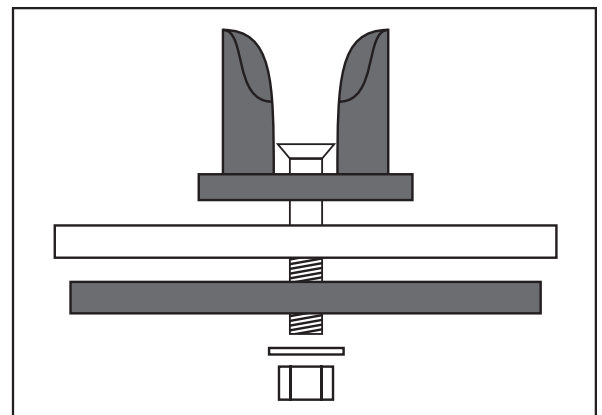

FIG. 5

